

FlameSheet™

A Revolution in Combustion Technology
for Power Generation Gas Turbines



FlameSheet™ enables fuel flexibility, lowers NOx and CO emissions, extends inspection intervals, and increases gas turbine load range.

PSM'S Premier Combustor Designed for Ultimate Flexibility

Superior Turndown, Fuel Flexibility, and Emissions Capability

Future-Proof your engine today! FlameSheet™ is the ultimate combustor solution to meet new operational needs. As the power generation market faces challenges from renewable energy penetration, low natural gas prices from fracking, and dynamic financial market changes, users must reevaluate their fleets to stay relevant. FlameSheet™ provides unparalleled flexibility, preparing your engine for both current operational demands and the future hydrogen economy.

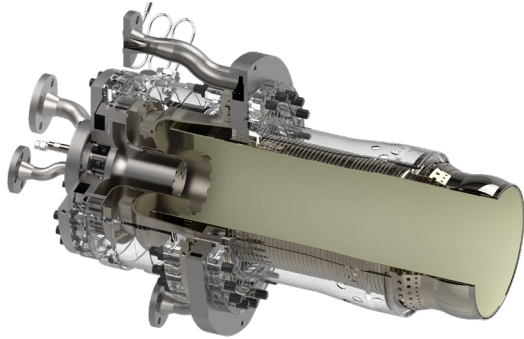

CROSS SECTION VIEW. FLAMESHEET™ IS NOW AVAILABLE ON MOST ENGINE MODELS

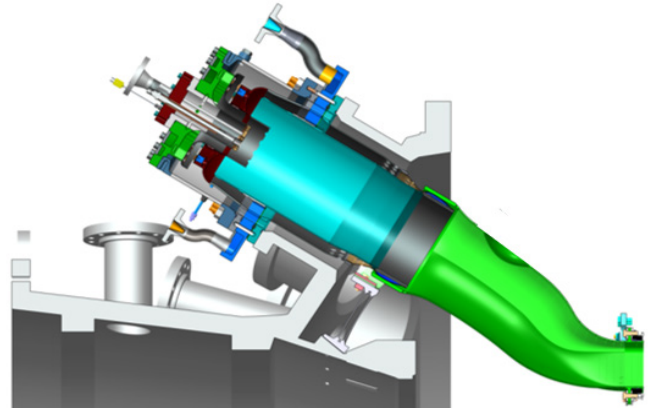

FlameSheet™ Benefits

- + Up to a 30% increase in GT operating load range with single digit NOx and CO
- + Optional low-load HRSG protection setting
- + Superior Fuel Flexibility:
 - » 30% Modified Wobbe Index
 - » Ideally suited for alternate fuel operation, including hydrogen, ethane, and propane
 - + Up to 40-80% Hydrogen blend*
 - + Up to 40% Ethanes (C2)
 - + Up to 10% Butanes (C4-C6)
 - + Up to 20% Propane (C3)
 - » PSM is progressing towards 100% Hydrogen capability!
- + NOx as low as 5ppm
- + Peaking power at constant NOx emissions
- + Dual fuel capable
- + Inspection intervals up to 32K hours / 1,250 starts
- + Compatible with existing GT controllers and fuel skids
- + Turndown as low as 26% (even lower with Exhaust Bleed!)

FlameSheet™: TWO Combustors in ONE

FlameSheet™ utilizes a simple, two-stage radially-inflow “combustor-within-a-combustor” design, enabling staged operation across various load conditions. At high loads, both combustors are active, with the outer combustor’s flame structure forming an annular “sheet of flame” around the inner combustor. At low loads, the outer combustor predominantly operates.

Leveraging trapped vortex stabilization aerodynamics, the outer combustor maintains excellent stability and sufficient heat at very low loads to consume CO, which typically limits low-load operation. The outer combustor operates with excellent stability and remains sufficiently hot at very low loads to consume CO (CO typically limits



FLAMESHEET™ IN PRODUCTION AT PSM WORKSHOP

How It Works

Flexibility

PSM leverages the combustor system to enable flexible operations. Below are options that can be retrofitted on traditional DLN or LEC systems:

- + Aerodynamic trapped vortex to ensure wide stability margin
- + Flame isolation – Combustor within Combustor to allow extended turndown operation
- + High pre-mixer exit velocities for tolerance to highly reactive fuels
- + Robust mixing techniques for improved fuel flexibility and tolerance to fuel Wobbe
- + index variation

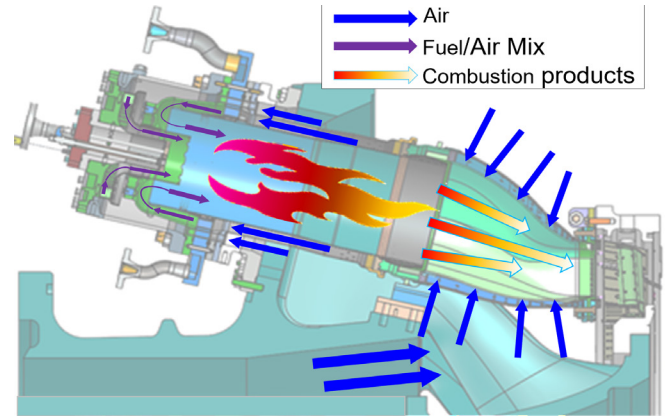

Superior Turndown, Fuel Flexibility, and Emissions Capability

PSM is the premier global gas turbine combustion engineering and service solution provider. We manufacture combustion systems that meet industry and market demands, enabling our customers to remain competitive in the current and future energy landscape. FlameSheet™ is the ultimate combustor solution for new operational needs.

As renewable energy penetration, low natural gas prices, and dynamic financial markets impact the power generation sector, operators must reassess their fleets to stay relevant. PSM's FlameSheet™ technology offers unparalleled flexibility while future-proofing traditional gas turbine power plants. This innovative solution addresses emerging trends such as:

- + Hydrogen 'power to gas' alternatives
- + Increased shale gas utilization
- + Ultra-low emissions requirements
- + Fleet revitalization as a cost-effective alternative to new unit installations

FlameSheet™ combustion systems are available for a wide range of gas turbine engines, including GE, Siemens-Westinghouse, MHI, and others.

Future-proof your engines today with the ultimate in combustion technology!

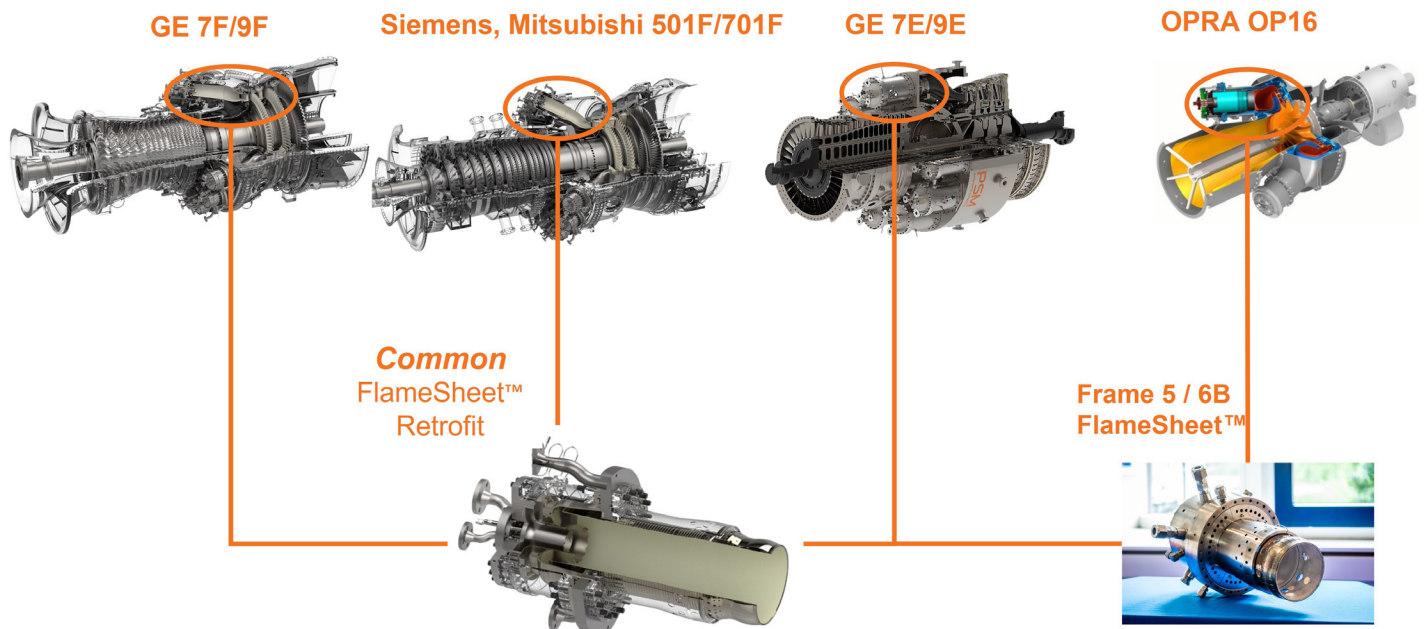

PSM - A Hanwha Company

The growing interest in the hydrogen economy is driven by the need to address climate change and transition to sustainable energy sources. However, challenges remain, including high production and storage costs, and extensive infrastructure requirements for distribution and transportation.

As a Hanwha subsidiary, PSM is uniquely positioned to leverage the expertise and resources of the Hanwha family to accelerate hydrogen development and adoption as a clean energy source. Hanwha's global presence and diverse business interests in areas like solar energy and defense provide PSM access to a wide array of technologies, markets, and partnerships.

Collaboration with Hanwha Q CELLS, a leader in large-scale solar projects, enables PSM to integrate hydrogen production with solar energy systems, fostering more sustainable and efficient energy solutions.

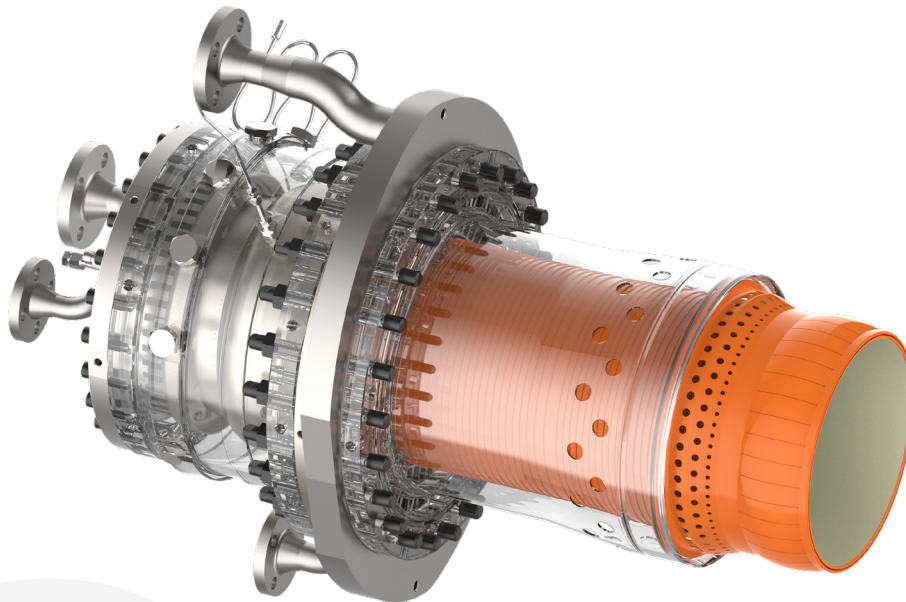

PSM
a Hanwha company

Thomassen Energy
a Hanwha company

PSM
Thomassen Gulf
a Hanwha company

Contact a PSM Sales Representative for additional information.
Phone: +1 561 354 1161
Email: sales@psm.com

www.psm.com | <https://thomassen.energy> | www.psm.com/ptg

© 2025 Power Systems Mfg., LLC (PSM), PSM, BV, and PSM. PSM, PSM, BV, and PSM are not an authorized distributor or representative of GE, Siemens, Mitsubishi, or Westinghouse. The data contained herein is provided for information purposes only. PSM, PSM, BV, and PSM make no representation, warranty or guarantee (whether expressed or implied) as to the accuracy or completeness of such data or any projected performance criteria.